

1. BREAK AND DEBURR ALL SHARP EDGES

2. MARK PART NUMBER AT CONVENIENT LOCATION ON BODY OF PART.

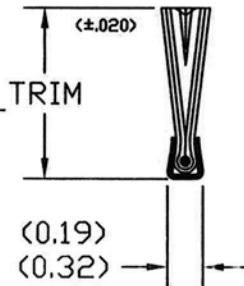
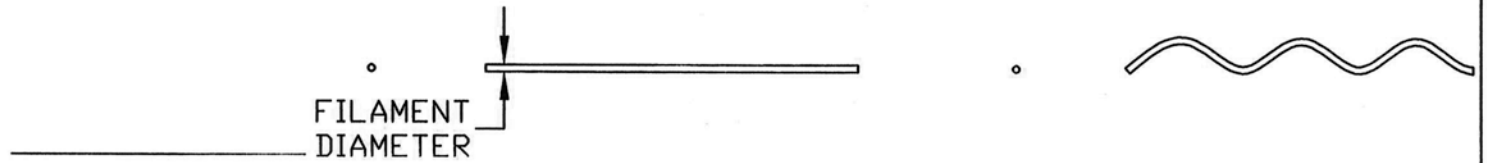

#4 3/16 (.019)
 #7 5/16 (.032)
 #10 7/16 (.044)

STRIP SIZE

TYPE: GALVANIZED
 STAINLESS STEEL

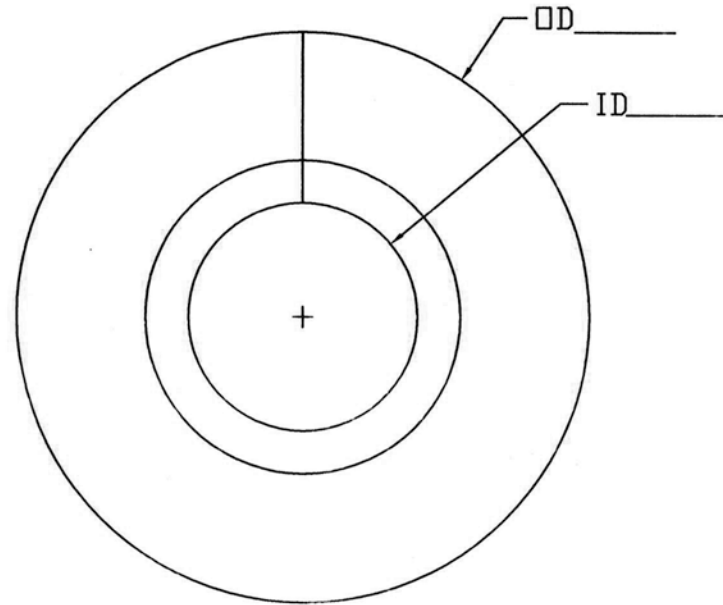
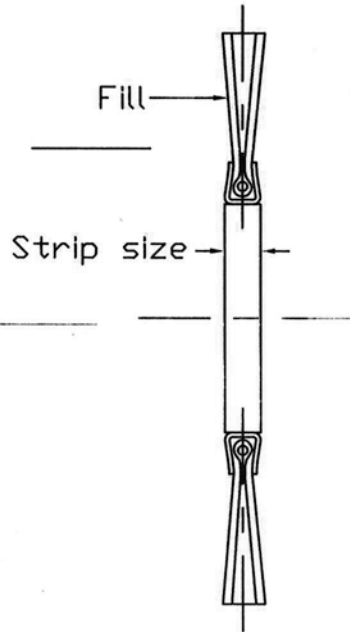

UNLESS OTHERWISE SPECIFIED

DIMENSIONAL TOLERANCES ARE:
 FRACTIONS 1/32
 2 PL DECIMALS $\pm .01$
 3 PL DECIMALS $\pm .005$
 4 PL DECIMALS $\pm .0005$
 ANGLES 30 MIN.

KD Manufacturing, Inc. 'A'

External Brush Ring

NAME

REL.

DONOT SCALE #ExtRingWebPg

REV.

	X	X	X
ITEM	QTY. EA	STOCK SIZE	DESCRIPTION
FINISH	HEAT TREAT		
THIS DOCUMENT IS THE EXCLUSIVE PROPERTY OF KD Manufacturing, Inc. IT SHALL NOT BE REPRODUCED WITHOUT WRITTEN PERMISSION			DWN. T.KLATT